



Historical Assessment of the Saka Tunggal Mosque in Banyumas: Study on the Single Column Mosque on Java Island, Indonesia

Arif Sarwo Wibowo & Shiro Sasano

To cite this article: Arif Sarwo Wibowo & Shiro Sasano (2016) Historical Assessment of the Saka Tunggal Mosque in Banyumas: Study on the Single Column Mosque on Java Island, Indonesia, Journal of Asian Architecture and Building Engineering, 15:3, 373-380, DOI: [10.3130/jaabe.15.373](https://doi.org/10.3130/jaabe.15.373)

To link to this article: <https://doi.org/10.3130/jaabe.15.373>



© 2018 Architectural Institute of Japan



Published online: 24 Oct 2018.



Submit your article to this journal [↗](#)



Article views: 120



View related articles [↗](#)



View Crossmark data [↗](#)



Citing articles: 1 View citing articles [↗](#)

Historical Assessment of the Saka Tunggal Mosque in Banyumas: Study on the Single Column Mosque on Java Island, Indonesia

Arif Sarwo Wibowo*¹ and Shiro Sasano²

¹ Assistant Professor, School of Architecture, Planning and Policy Development, Bandung Institute of Technology, Indonesia

² Professor Emeritus, Tokyo Institute of Technology, Japan

Abstract

Currently, there are four mosques on Java Island recognized as *Saka Tunggal* Mosques, which employ a single wooden column as the main column, placed at the center of the prayer hall to support the roof. This unique structural system, when compared to the traditional four-column system, is remarkable even if its style is exceptional for mosques on Java Island. This study aims to provide scientific data and promote the local government's understanding about the importance of the *Saka Tunggal* Mosques by focusing on the one in Banyumas, which is placed at a cultural heritage site, founded in 1871. This article was categorized as a part of an effort to revive and restore important architectural heritage sites in Indonesia. The discussion in this article will be composed of three parts. The first part will provide a description of the current condition of Banyumas's Mosque. The second part will illustrate the renovations of the Mosque in chronological order. The third part will describe the three other *Saka Tunggal* Mosques in order to differentiate the specific characteristics of Banyumas's Mosque from the context of its structural system.

Keywords: wooden architecture; old mosque; cultural heritage; single column; preservation

1. Introduction

Historically significant mosques in Indonesia are often not registered as cultural heritage sites and as a result, are not given clear guidelines for preservation. In 2012, 602 buildings were registered as national heritage sites, covering various categories, including wooden traditional buildings, colonial buildings, fortresses and other categories¹. Mosques constitute the predominant category, especially on Java Island, well known as the island of the *Wali Sanga* (nine saints).

Mosques have been constructed on Java Island since ancient times. There are four mosques still left on the island that are recognized as single-column mosques, which are called *Saka Tunggal* Mosques or *Soko Tunggal* Mosques in local dialects². Those mosques are located in four cities: Banyumas, Cirebon, Kebumen and Yogyakarta. These are evaluated to be unique mosques due to employing a single column structural system that conspicuously contrasts to a conventional, traditional structural system, in which four columns support a roof, known as "*saka guru*".

The "*saka guru*" structural system is commonly used in traditional Javanese houses, as well (Fig.1.). The system of the four columns in "*saka guru*" implicates symbolical meaning to represent each cardinal point, while the single column is believed to symbolize the Islamic doctrine of monotheism. In more practical terms, the single column mosque also adds space, allowing more flexible movement during prayer for the congregation.

Besides taking notice of single column mosques' uniqueness, this study intends to enhance the scholarship surrounding the preservation of traditional architecture through historical assessment and also aim at reaching out to the local government by providing scientific data to promote their preservation activity.

To begin preservation work on the *Saka Tunggal* Mosque of Banyumas, it is important to elucidate the original shape and design of the mosque. Since there are customarily neither written documents nor old pictures of the mosque in such a country, including Indonesia, one useful method for approaching this issue, even if being reluctantly allocated to a certain extent, relies on people's inherited memories under the verification of interviewing and brainstorming, whereby the local people, especially the mosque's *Imam*³, recall various events including verbal legends and folklore whenever they bristle with detail, for supplementing a scientific method by investigating the original structure under the field survey and, then, by re-drawings that precisely

*Contact Author: Arif Sarwo Wibowo, Assistant Professor, School of Architecture, Planning and Policy Development, Bandung Institute of Technology, Jalan Ganesa 10, Bandung, Indonesia 40132

Tel: +62-22-2504962 Fax: +62-22-2530705

E-mail: wibowo@ar.itb.ac.id

(Received April 8, 2015 ; accepted July 20, 2016)

DOI <http://doi.org/10.3130/jaabe.15.373>

reproduce the current condition of the mosque. Furthermore, a supplemental approach of a typological study is most effective for clarifying its specific features by being compared with the other mosques, whose style and design indicate similarities⁴.

The discussion in this article embodies three parts: the first part describes the current condition of the mosque; the second part illustrates the modifications the mosque had in chronological order; the third part compares the other three mosques in Cirebon, Kebumen and Yogyakarta in order to distinguish the structural system of each mosque. All data was attributed to the assignment in the field survey and the interview with the *Imam*, the *Kuncen*⁵ and elderly local inhabitants around the Mosque concerned in the mosque history, renovation/maintenance activities and current condition.

2. Current Condition

The *Saka Tunggal* Mosque of Banyumas⁶, besides being a purely religious institution, is sometimes utilized for accommodating domestic pilgrims and visitors. The house of the *Kuncen* was built at the north side of the mosque, while the *Imam* lives at the south side. Not far from the mosque, at the northwestern side, there are tombs of the ancestors. The mosque is surrounded by a forest in which monkeys live.

The mosque has been maintained and is relatively clean, but decay has been found in the roof section. The mosque consists of three rooms (Fig.5.). The first room on the east side, called *pendapa*⁷, is currently used for general activities. The *pendapa* occupies an area of 7m long by 10.5m wide and is also equivalent to the prominent anteroom of the mosque. In the *pendapa*, the floor is separated into two parts with one being 30cm higher than the other. A two steps stair is disposed at the center along the main axis of the mosque. The floor of the main room, the prayer hall, is 66cm higher, by four steps, than the *pendapa*. The prayer hall, measuring 9m long by 10.5m wide, is separated into two parts, the northern side which serves males (9m long by 7.5m wide) and the southern side which serves females (9m long by 3m wide).

The western brick wall of the prayer hall is 20cm thick; while the *pendapa's* eastern side is 15cm thick. Teak timber is the main structural material, and jackfruit timber was used for auxiliary components. Among the present structural materials, only the main column and the *tumpangsari*⁸ frame-structure are presumed to be original, based on their state of aged deterioration, as well as on the testimony of the *Imam*, who has no memory of replacement, except for a new layer of paint, while other columns and beams were replaced during separate restorations undertaken in the past⁹. The exterior brick wall was painted a light blue color.

The roof framework is composed of jackfruit timber and is covered by a metal tin roof. The entire interior floor is covered with white ceramic tiles, sized 30cm by 30cm, except for the main prayer hall where the carpets

conceal the tiled floor (Fig.3.). Woven bamboo panels are employed for the ceiling, as well as partition walls between the rooms. All visible wooden and bamboo components are coated with glossy varnish. The single

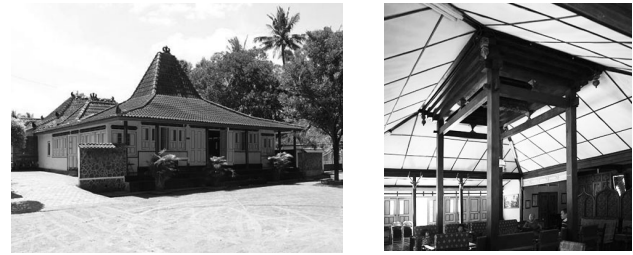

Fig.1. Traditional Javanese House, the Notosukardjo House in Yogyakarta, Constructed in the 19th Century, Employs a Four Column Structural System, Known as *saka guru*



Fig.2. Java Island Map: Cities Location



Fig.3. The *Saka Tunggal* Mosque of Banyumas

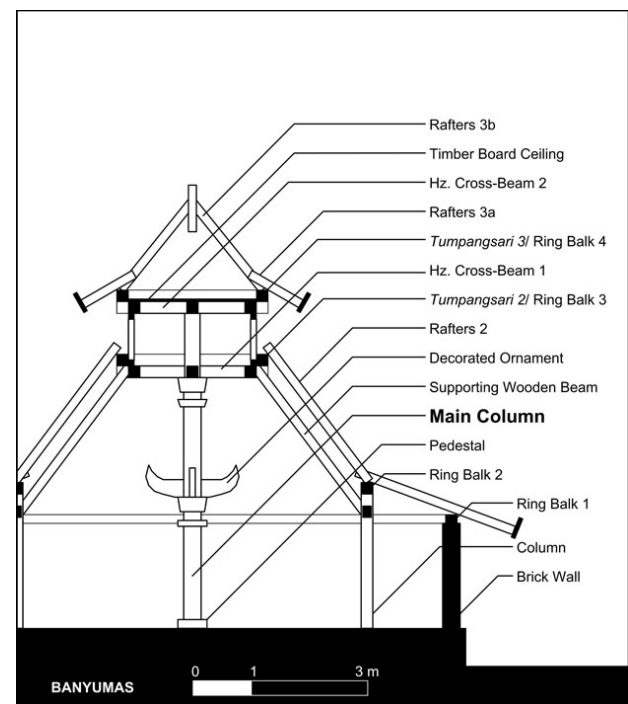

Fig.4. Section of the *Saka Tunggal* Mosque of Banyumas

main column at the center of the main prayer hall is fully carved and finished with colorful paint (green, red, yellow). It is made from a single, solid piece of wood, sized 24cm by 24cm at the base, without any joints, and is 525cm high; it supports the roof at the center of the room, together with the other 12 columns, sized 11cm by 11cm at the base (Fig.5.).

There are two ablution facilities. The main ablution facility and the toilet were built on the east side as a separate building and are connected to the mosque through a breezeway. The second ablution facility is also available for males on the north side of the breezeway, which was installed in 1976 (Fig.5.)¹⁰. The present ablution facilities are made of brick and finished with ceramic tiles.

3. Morphological Conversion Based on Chronological Order

Based on the inscription carved on the main column, the Saka Tunggal Mosque of Banyumas is presumed to have been founded in 1288 (Fig.3., inset at the lower left); however, it is not clear if the date refers to the Hijra or to the Gregorian calendar system. Considering the fact that it was written in Arabic characters, it presumably refers to the Arabic Hijra calendar. If so, the incised date is equivalent to the year, 1871. Even so, local people still believe that it refers to the Gregorian calendar or that the mosque was constructed much earlier than the well-known Demak Great Mosque, which was constructed in 1479¹¹. Even though the date on Banyumas's Mosque is not older than the Demak Great Mosque, there is evidence that the mosque was constructed earlier than the date of the inscription, based on the story that Raden Joko Kahiman, appointed as the first Banyumas Regent in 1582¹², had studied Islamic religion in this mosque¹³. It might be possible that the inscription indicates a date of a restoration in 1871 when a complete or partial renovation on the single main column had to be replaced by a new one due to deterioration of the timber¹⁴. Taking all of this contradictory data into account, the mosque is presumed to have been built before the inscription date, regardless of its current structural system. A wooden shingle roof was presumably used to cover the roof, as commonly performed on traditional mosques, such as the Demak Great Mosque¹⁵. Despite the disputed date of original construction, it is rather difficult to completely renounce, due to the above auxiliary statements, that this mosque is still one of the oldest mosques on Java Island. According to testimony by the *Imam* of the mosque, the renovations of the mosque were undertaken in 1887, 1976, 1981, 1996 and 2000¹⁶.

In addition, the *Imam* stated that wall-panels of woven bamboo on the *pendapa* and metal tin roof were fixed during the renovation of 1887. At the 1976 renovation, the floor level of the mosque was raised by about half a meter. The woven bamboo wall-panels were replaced with brick walls, while the interior partitions

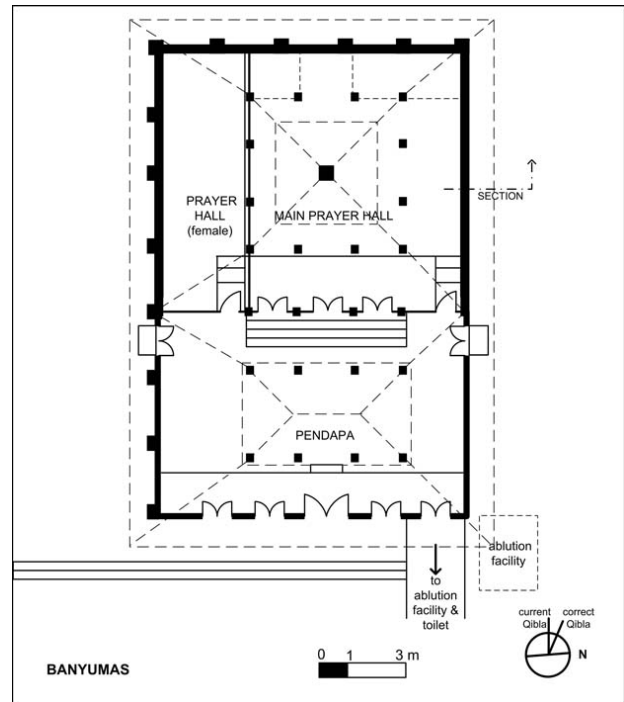

Fig.5. Plan of the *Saka Tunggal* Mosque of Banyumas

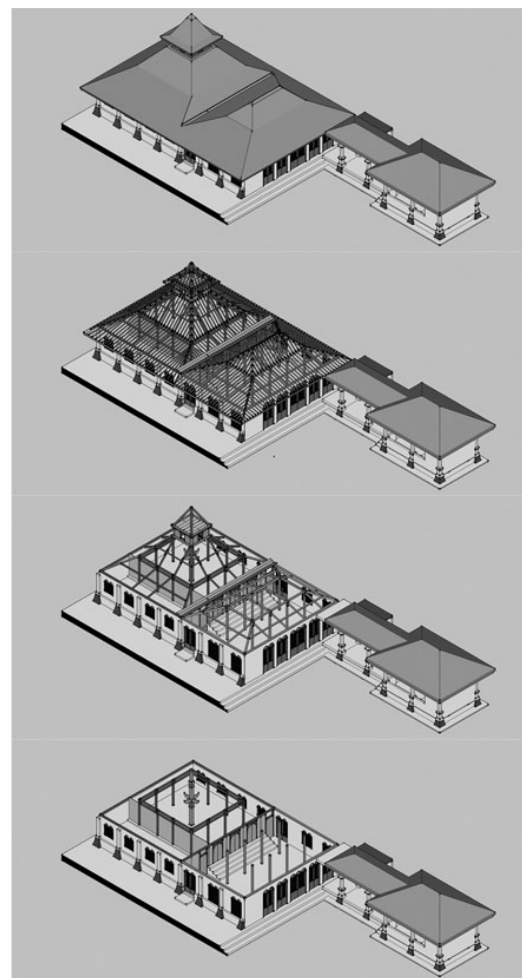

Fig.6. Digital Three-dimensional Illustration of the Current Condition of the *Saka Tunggal* Mosque of Banyumas

were still composed of woven bamboo fixed within wooden frames. Not long after that, in 1981, the mosque was equipped with electricity without any affect on the structure's architecture. In 1996, the roof was renovated once again by adding palm fibers on the existing roof.

Unlike the traditional construction-system, the palm fibers' arrangement was just added on the top, covering the metal tin roof. In 2000, toilet and ablution facilities were built on the eastern side, connected to the mosque through a breezeway, which replaced the former ablution facility for females in the southern side of the mosque, and added a toilet onto it¹⁷. Regarding these renovations, the *Imam* testified that there were no records mentioning the single column at the center of the prayer hall. Therefore, the column has most likely been maintained without any alteration since 1887.

Furthermore, from field survey inspections, several alterations were discovered in the mosque, apart from the statement of the *Imam*. Since the thickness of the wall around the *pendapa* is thinner than in the prayer hall, the wall of the *pendapa* was probably installed in a different period than the prayer hall. Judging from the fact that older bricks are usually bigger in size – resulting in an increase in wall thickness – the thick brick wall of the prayer hall building was likely constructed earlier than the wall of the *pendapa*.

Based on the chronology of the mosque's renovations the present edifices were achieved through four stages of past renovation. Therefore, by subtracting every recorded and/or testified modification in each stage, one by one, back to before 1887, the estimated reconstructions of the mosque can be displayed in Fig.7. as a three dimensional digital illustration.

4. Structural System of the Other Three Mosques

As mentioned above, the uniqueness of the single supporting column, employed in the *Saka Tunggal* Mosque of Banyumas, is also present in the three other *Saka Tunggal* Mosques in Cirebon, Kebumen and Yogyakarta.

Cirebon's mosque, also known as Langgar Alit, is presumed to have been constructed in 1479¹⁸. Despite its small size, a 7.4m by 7.4m-main prayer hall and an 84cm floor level raised from the entrance level (Fig.8.), the building is used for daily religious activities, such as reciting the Holy Quran and Islamic studies by the nobles. The size of the main column is 30cm by 30cm at the base and 380cm in height. The building construction system for supporting the roof consists of the main single column at the center and another 9 columns surrounding it; 3 of the 9 columns are attached to the brick wall (Fig.10.). The roof structure is supported by the single column with four consoles (Fig.9.). The stepwise ceiling system, called *tumpang Sari*, is fixed under the topmost roof structure.

Kebumen's mosque is presumed to have been constructed in 1719¹⁹. The mosque consists of the prayer hall and *pendapa*. The prayer hall's dimensions are 9m

by 9m, while the *pendapa* is 5m by 9m (Fig.13.). In 1822, the roof was changed from palm fibers to tile. Then, woven bamboo walls were replaced by brick walls about a century later²⁰. At present, modern materials, such as 30cm by 30cm ceramic tiles and modern style windows are used to cover the mosque (Fig.11.). From the inspection during the field survey, it can be judged that the mosque's original state is no longer visible, except for the single column as the main structure. The mosque comprises a very simple main framework without *tumpang Sari* (Fig.12.), as seen in Banyumas. The main column, 28cm by 28cm at the base and 433cm high, is made of plain solid wood without ornaments, whereas the 4 consoles supporting the beam are fully carved. The wall thickness of the prayer hall measures 31.5cm, while the *pendapa* measures 20cm.

Yogyakarta's mosque was constructed between 1967 and 1973²¹ and inaugurated by the Sri Sultan Hamengku Buwono IX (King of Yogyakarta at that time). Generally, there have not been many modifications in the last four decades based on the original drawings²² (Fig.17.). The single column (46cm by 46cm at the base and 550cm high) is half carved, while the four consoles are all fully carved supporting the *tumpang Sari* framework (Fig.15.). The

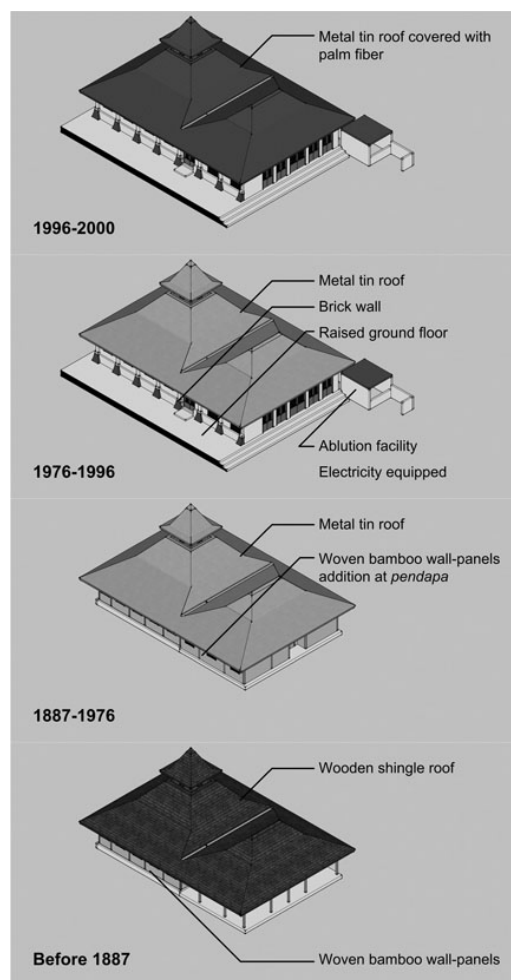

Fig.7. Digital Reconstruction of the *Saka Tunggal* Mosque of Banyumas, Based on Reverse Chronological Order

tumpangsari, a stepwise ceiling, is joined to the single column with the other four consoles. The mosque consists of four rooms. At the front side, there is a *pendapa* measuring 8m by 16.5m (Fig.16.), while the prayer hall, 10m by 10m, occupies the center of the building. At the northern side there is a room, 10m by 3.3m, for males, and there is a same sized room on the south side for females. The wall thickness of the main hall and the other two side rooms is 30cm.

5. Differences between the Four Mosques

There are some differences in the structural system of these four mosques, although the single column extends to the upper part of the roof structure as a component that transfers the load. The single column directly supports the ceiling under the topmost roof, *tumpangsari* (bracket), in the two mosques, Cirebon's and Yogyakarta's; whereas the flat ceiling covers the central section, supported by a single column in the other two mosques, Banyumas's and Kebumen's. Although there are two types of ceiling system, the structural system of the single column distinctively contrasts with Banyumas's and the other three; Banyumas's mosque transfers the load from the roof structure directly to the basement through the single column without any consoles (Fig.4.). A fragile structural system against instability of the load is supplemented by eight wooden beams joined with the surrounding columns to maintain the balance of the structure. This system, comparable to an umbrella without its braces, may well be said to be immature in structure, to a considerable extent, due to the lack of stability, particularly in contrast to the other three mosques. In fact, in these three mosques, the upper roof structure is supported at five points, joined with the main single-column with four consoles, which branch out from the single column to maintain the balance and stability of the upper roof structure (Figs.9., 12. and 15.). In contrast, in Banyumas's mosque, the load from the upper roof structure goes through the *tumpangsari* 2/ring balk 3, and then, the horizontal cross-beam, and finally is transferred to the single column in the center (Fig.4.). In the other three mosques, in addition to the above-mentioned system, the dispersed load is transferred through four consoles to the main column without an assistant component of cross-beams (Figs.9., 12. and 15.). Therefore, the system employed in these three mosques acquires, by and large, more structural stability than in the case of the Banyumas Mosque.

In a sense, the system employed in the three mosques seems much more sophisticated and logical than Banyumas's in regard to the concept of the structural evolution, even though the so-called currency of construction dates is not necessarily congruent with the rational consideration; logically, the primitive composition employed in Banyumas's seems to have progressed to the deliberate, developed structural system that is found in the other three mosques. Thus,



Fig.8. The *Saka Tunggal* Mosque of Cirebon

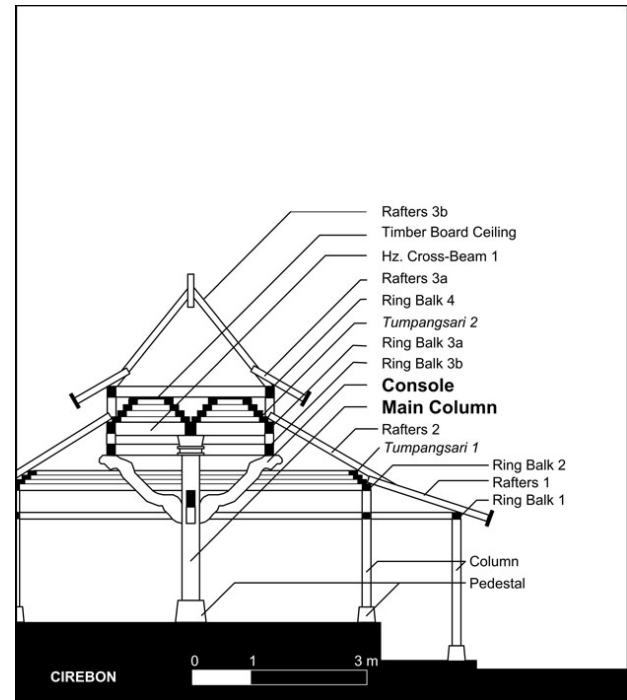

Fig.9. Section of the *Saka Tunggal* Mosque of Cirebon

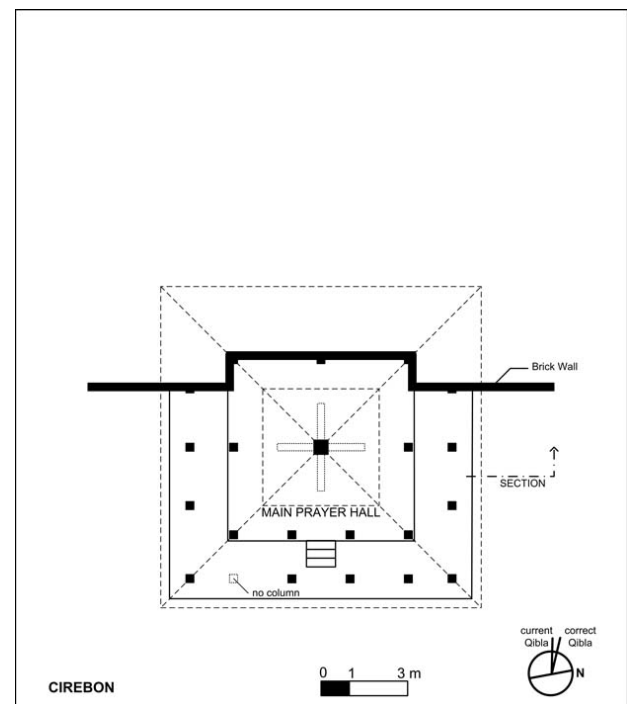

Fig.10. Plan of the *Saka Tunggal* Mosque of Cirebon

Banyumas's mosque is likely to have been constructed earlier than the other three, in which the construction date of Kebumen's is approximately reliable.

In Kebumen's mosque, since the recorded dates at the restoration, in particular at the 1822 restoration of the roof, make no reference to the replacement or management of the single column, it may well be trustworthy that its system of the single column was preserved more or less in the beginning of the 19th century, in the same state at present, whatever its shape and style were. In addition, different from Cirebon's and Yogyakarta's, Kebumen's employs the simple ceiling system above the main column without using stepwise *tumpangsari* as seen in Banyumas's. Therefore, as an evolutionary stage in architecture, Banyumas's is presumed to have been allocated before Kebumen's in chronological order. In other words, the single column system employed in Banyumas is estimated to have a distinctive difference against the other three cases, in a sense, as indicating a rudimentary stage in the structural evolution of this style, even though the recorded or testified date of its construction contradicts the above verification.

6. Conclusion

The structural system that employs a wooden single column to support a roof structure is assigned only to four mosques on Java Island. Though at a glance displaying similarities in their scheme, they are classified into two distinctive types under a combination of building components. The *Saka Tunggal* Mosque of Banyumas is distinguished from the other three, regarding not only a primitive style that contrasts with the others employing four consoles that must have likely yielded a certain structural advantage, but also to an unrefined ceiling style without a decorated, stepwise ceiling, known as *tumpangsari*. Consequently, the system employed in the other three mosques may well be said to be more elaborate and refined if notice is taken of their architectural evolution, despite the humble appearance of the mosque in Kebumen. In this sense, the style of Banyumas's might allude to a certain primordial stage in the evolution of Java's mosques by applying the single column system, regardless of what is inscribed on the column concerning its construction date. As far as the historical data on Kebumen's mosque is reliable to some extent, the system of the single column in Banyumas's mosque, as a forerunner of its style, seems to have come into existence at the latest at the beginning of the 19th century.

In this context, the *Saka Tunggal* Mosque of Banyumas is certainly worthy of preservation for its importance to the historical context of Indonesian architecture. Therefore, this article not only clarifies its specific uniqueness and historical value but also the essential requirement that it be restored and named as a national heritage site to ensure its preservation for generations to come.



Fig.11. The *Saka Tunggal* Mosque of Kebumen

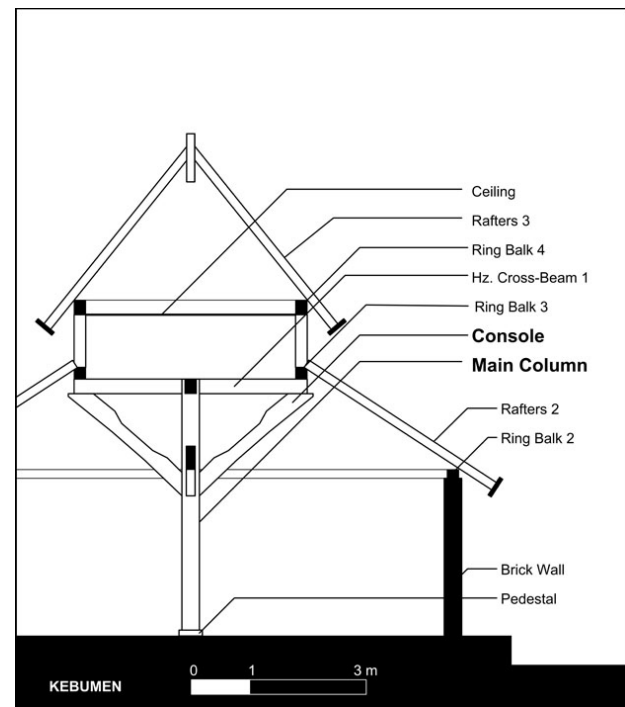

Fig.12. Section of the *Saka Tunggal* Mosque of Kebumen

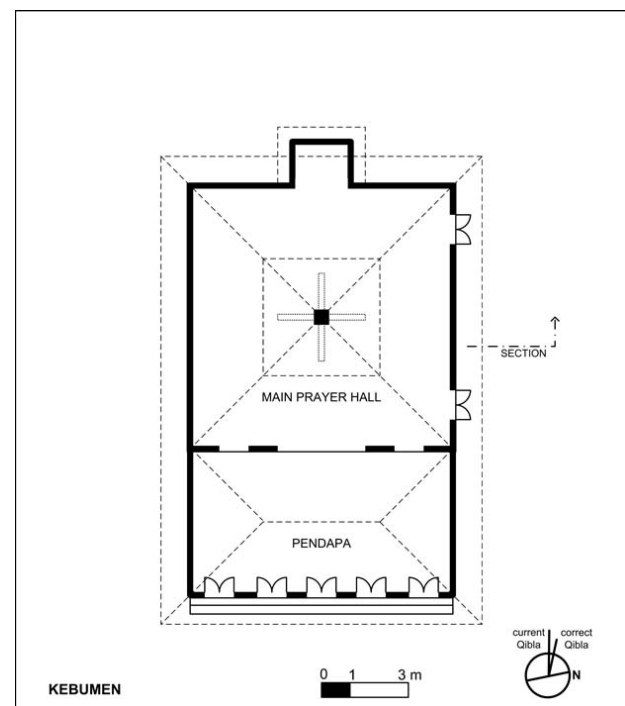

Fig.13. Plan of the *Saka Tunggal* Mosque of Kebumen

Notes

- ¹ Source: Indonesian Heritage Inventory, non-profit organization. <http://heritageinventory.web.id/page/index/3> (September 3rd, 2014).
- ² One *Saka Tunggal* Mosque, also located in Banyumas, constructed in 1913, is excluded from the discussion since its main column is made of other material than wood. All four mosques discussed in this article employ wood material as the main column.
- ³ *Imam* in this article refers to the local Muslim leader who leads the daily prayers in the mosque. *Haji Sulam* is the Imam of Saka Tunggal Mosque in Banyumas. Interviews were done in August 11th, 2013 and May 26th, 2014, with an estimation of three hour on each session.
- ⁴ Field surveys were conducted in August 2013 and May 2014.
- ⁵ *Kuncen* means the caretaker of the mosque.
- ⁶ The mosque is located in *Desa* Cikakak, *Kecamatan* Wangon, *Kabupaten* Banyumas, Province of Central Java, Indonesia. In Indonesian governance order, *Desa* is the lowest government level in the rural area, which means village, equivalent to *Kelurahan* in the urban area. At the second level, there is *Kecamatan*, applied for both the rural and urban areas, means Sub-District. At the third level, there is *Kabupaten* for the rural area, literally means Regency, while in the urban area called *Kotamadya*, which means City. The fourth level is *Propinsi* or literally means Province.
- ⁷ *Pendapa* or *pendopo* literally means additional building. In Javanese traditional houses, *pendapa* is used as guest room or for any semi public activities. Originally *pendapa* is a roofed space supported by several columns without wall or partition.
- ⁸ *Tumpang Sari* is the timber bracketing structural system above the main column in multi-layers arrangement.
- ⁹ Source: interview with the *Imam* and the *Kuncen* of the *Saka Tunggal* Mosque of Banyumas on May 26th, 2014.
- ¹⁰ *Ibid.*
- ¹¹ Budi B.S. (2006) A Study on the History and Development of the Javanese Mosque Part 3: Typology of the Plan and Structure of the Javanese Mosque and Its Distribution. *Journal of Asian Architecture and Building Engineering*, 5 (2), p. 232.
- ¹² Raden Joko Kahiman was son in law of Adipati Warga Utama I (Duke of Kadipaten Wirasaba). He was appointed as Duke after the dead of Adipati Warga Utama I. Raden Joko Kahiman divide the territory into four region and share with Adipati's descendants in 1582. He ruled one of the regions and named it Banyumas. Source: Wijono, Soegeng and Sunardi (2006) *Banjoemas Rimajtmoe Doeloe (Banyumas First History)*. Daya Mandiri Production.
- ¹³ Source: interview with the *Imam* and the *Kuncen* of the *Saka Tunggal* Mosque of Banyumas on May 26th, 2014.
- ¹⁴ The age structure of wooden buildings in the humid tropics reached 30-60 years.
- ¹⁵ Soekmono, R (1973) *Pengantar Sejarah Kebudayaan Indonesia (Introduction to History Culture of Indonesia)*. Jakarta: Yayasan Kanisius
- ¹⁶ The date and specific contents of each renovation were obtained from the *Imam* of the Mosque. In addition to his memory in his childhood, he inherits the history of the mosque from his ancestors passing through generations as a patrimonial obligation.
- ¹⁷ The former ablution facility for female was on the southern side, detached from the mosque, while for the male is on the northern side attached to the main building as shown on the Fig.6. still maintained until now.
- ¹⁸ Budi B.S. (2006), *op. cit.*, p. 233
- ¹⁹ *Ibid.*
- ²⁰ Source: interview with the *Imam* and the *Kuncen* of the *Saka Tunggal* Mosque of Kebumen on May 30th, 2014.
- ²¹ Source: Mintoboedjo R.Ng. (1973) *Sejarah Singkat tentang Pembangunan Masjid "Sokotunggal" Taman Keraton Yogyakarta (Brief History of "Sokotunggal" Mosque Construction Work at Taman Keraton Yogyakarta)*. Yogyakarta: Sokotunggal Mosque Construction Committee. Issued on February 28th, 1973, as the committee report of the construction work.
- ²² The original architectural drawings are being preserved by *Haji M. Hadjir Digdarmodjo*, the former secretary of the mosque construction committee in 1967.



Fig.14. The *Saka Tunggal* Mosque of Yogyakarta

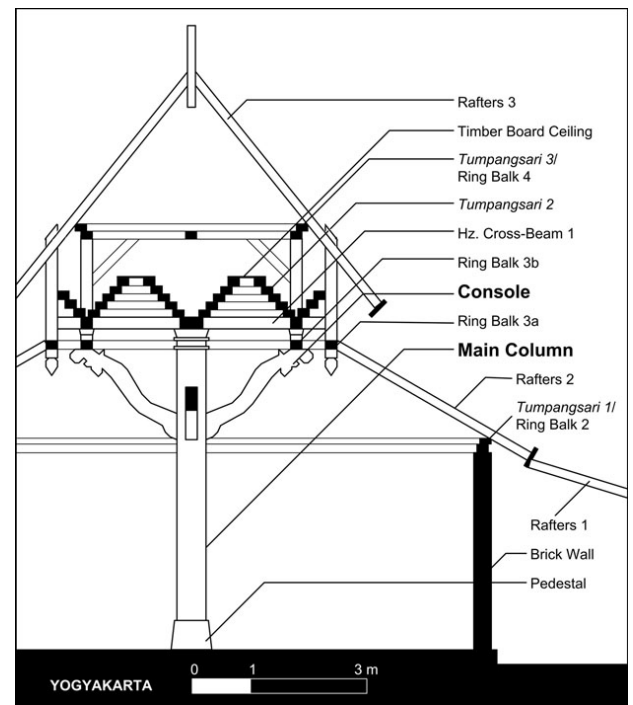

Fig.15. Section of the *Saka Tunggal* Mosque of Yogyakarta

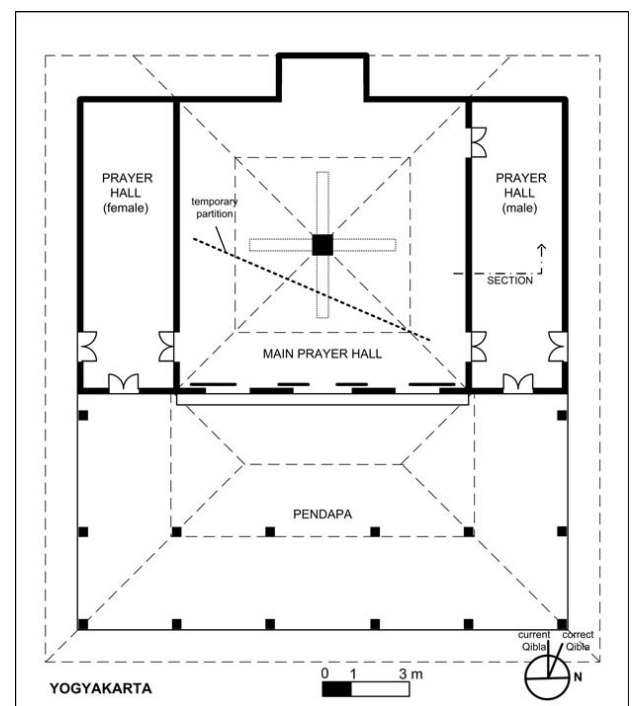

Fig.16. Plan of the *Saka Tunggal* Mosque of Yogyakarta

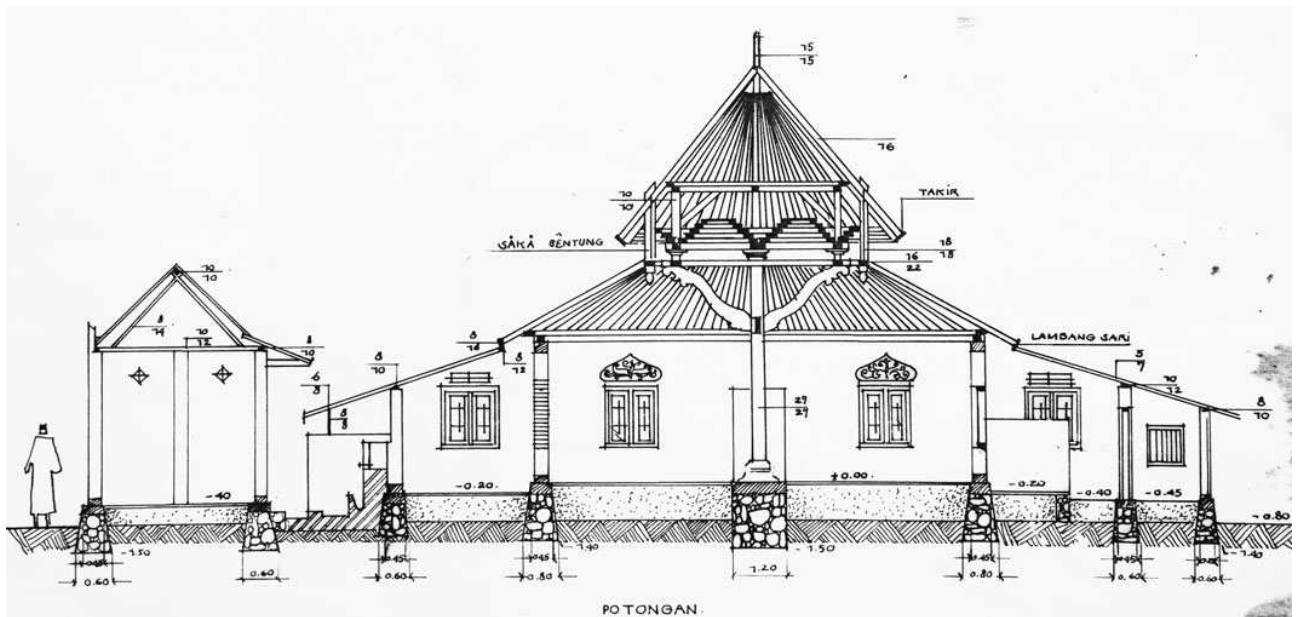

Fig.17. Original Drawing of the *Saka Tunggal* Mosque of Yogyakarta (Section)

References

- 1) Adrisijanti, I. (1977) Telaah Singkat tentang Bangunan Bertiang Satu (Study of Single Column Building). Pertemuan Ilmiah Arkeologi (Archeology Scientific Meeting). Jakarta: Pusat Penelitian Purbakala dan Peninggalan Nasional, pp.470-476.
- 2) Budi, B.S. (2001) Masjid 2000 CD-ROM. Bandung: Institut Teknologi Bandung.
- 3) Budi, B.S. (2006) A Study on the History and Development of the Javanese Mosque Part 3: Typology of the Plan and Structure of the Javanese Mosque and Its Distribution. *Journal of Asian Architecture and Building Engineering*, 5 (2), pp.229-236.
- 4) Direktorat Urusan Agama Islam, Dirjen Bimas Islam dan Urusan Haji Departemen Agama RI (1988) Masjid-masjid Bersejarah di Indonesia (Historical Mosques in Indonesia), Vol. I & II. Jakarta: Departemen Agama RI.
- 5) Elba, M.Y. Masjid Tradisional Jawa (Traditional Mosque in Java).
- 6) Mintoboedjo R.Ng. (1973) Sejarah Singkat tentang Pembangunan Masjid "Sokotunggal" Taman Keraton Yogyakarta (Brief History of "Sokotunggal" Mosque Construction Work at Taman Keraton Yogyakarta). Yogyakarta: Sokotunggal Mosque Construction Committee.
- 7) Soekmono, R (1973) Pengantar Sejarah Kebudayaan Indonesia (Introduction to Culture History of Indonesia). Jakarta: Yayasan Kanisius.
- 8) Wijono, Soengeng and Sunardi (2006) Banjoemas Rimajamtmoel Doeloe (Banyumas First History). Daya Mandiri Production.