



CIVIL ENGINEERING

Effect of piles on the seismic response of mosques minarets

Mohamed Ahmed Abdel-Motaal *

Ain Shams University, Egypt

Received 25 February 2013; revised 26 May 2013; accepted 12 June 2013

Available online 31 July 2013

KEYWORDS

Minarets;
High-rise building;
Piles;
Equivalent linear dynamic analysis;
Soil–structure interaction;
Free field

Abstract Minarets seismic behavior is not similar to other known structures, because of their unique characteristics such as slenderness, shape, and supporting system. This study is devoted to investigate pile foundation effects on minarets dynamic response. An advanced finite element models were employed to simulate this sophisticated problem. The analysis procedure is essentially 2-D model enhanced to satisfy the requirements of 3-D problems, using transmitting and viscous boundaries. Root mean square procedure is implemented to minimize the needed computer memory. The model has a main advantage of considering the full interaction between soil, foundation, and structure. Three artificial earthquakes' time histories were used as control motions at the bed-rock surface.

Minaret (60.0-m height) was studied to investigate the effects of soil stiffness, pile length, diameter, and arrangement, on the minaret and pile dynamic behavior. Comparison between study results and conventional analysis method is illustrated. Study results, discussion, and conclusion are given.

© 2013 Production and hosting by Elsevier B.V. on behalf of Ain Shams University.

1. Introduction

Mosque minarets are the most characteristic features of the Islamic architecture. Functionally, the minaret is an elevated structure intended for the Adhan crier as he summons people for prayer [1]. Recently, it became a tradition to attach a macerate to the religious construction. Along fourteen centuries, a lot of masonry minarets have been constructed in a variety of

forms. Nowadays, the minarets are constructed from reinforced concrete that enabled both the architecture and the structural engineer to innovate and design high-rise minarets. One of the most important problems facing the structural designer is the dynamic response of such structure under lateral loads, especially under the effect of earthquake excitation.

The soil contact stress due to the heavy weight of these long minarets, over a relatively small area, may exceed the bearing capacity of the shallow soil layers. As a result, the choice of using pile foundation arises as one of the most convenient solutions. In addition, it has also a major role on structural stability (sliding and overturning stability), under lateral loads.

This study is devoted to investigate the effect of the pile foundation on the seismic response of the minarets structure. A wide range of dry sand formation (loose to very dense) is selected to simulate the upper sand formation. An extensive study has been carried out to investigate the effect of pile

* Address: Department of Structural Engineering, Faculty of Engineering, Ain Shams University, Abbasia, Cairo 11517, Egypt. Tel.: +20 2 23054302, +20 12 73 72897; fax: +20 2 23054115.

E-mail address: abdelmotal@yahoo.com.

Peer review under responsibility of Ain Shams University.



Production and hosting by Elsevier

length, diameter, arrangement, and soil stiffness on the dynamic response of the minaret. Study has been extended to investigate factors affecting the fixation degree of the structure supports (foundation) and hence their impacts on the minaret fundamental periodic time (FPT) and the shear base. Moreover, the developed bending moment in the pile shaft is assigned to establish the effect of pile length and diameters. Sensitivity study is carried out to establish the optimum and economic design. Comprehensive comparison between numerical model results and conventional analysis method is illustrated. Study results, discussion, and conclusion are given.

2. Previous studies

Elwan [2] studied the response of historical masonry minarets. The study was directed toward the seismic analysis of the minaret of Al-Ghuri Mosque (46 m height), ancient Cairo, Egypt. A numerical model has been used using Drain-2DX code. Finally, a simple and robust method for the evaluation of the safety level of masonry minarets was suggested.

Chmielewski et al. [3] evaluated the natural frequencies and natural modes of 250 m high-multi-flue-industrial chimney, located in Opole power station, using finite element model and considering the flexibility of the soil. The analytical results were compared with experimental work using full-scale experimental investigation of the free vibration response. Study results established that soil flexibility under the chimney foundation has influence over natural modes and natural period.

Acar et al. [4] studied the seismic response of a reinforced concrete representative minarets located on the four different subsoil classes defined in the Turkish Earthquake Code (2007). Finite element was used considering the design spectra defined by the Turkish Earthquake Code. Analysis results showed that the dynamic response of the minarets changes significantly depending on the soil condition, where the maximum lateral displacement, in case of soft soil, was 80% larger than very rigid soil.

Dogangun et al. [5] investigated the dynamic behavior of historical unreinforced masonry minarets. Three representative minarets with 20, 25, and 30 m height were modeled and analyzed using two ground motions recorded during 1999 Kocaeli and Duzce, Turkey Earthquake. The modal analyses of the models showed that the structural periods and the overall structural response were influenced by minaret height and spectral characteristics of the input motion.

Sezen et al. [6] studied the probable cause of the extensive damage to reinforced concrete minerals (30 m height) by reviewing the observed failure modes and their seismic performance during 1999 Kocaeli and Duzce, Turkey Earthquake. Through dynamic analysis, the effects of spiral stairs, door opening, and balconies on dynamic behavior were examined.

Haciefend and Fahri [7] presented a stochastic seismic response analysis of masonry minarets subjected to random underground blast and Earthquake-induced ground motion, using three-dimensional finite element models. They conducted a parametric study to estimate the effects of the blast-induced ground motion on the stochastic response of the minaret. Three different soil types (soft, med. and firm soils) were considered. Study results showed that the underground blast and earthquake effects cause the stochastic behavior of minarets to change considerably.

Tabeshpour [8] carried out a nonlinear dynamic analysis of chimney-like towers. The significance of this study is mainly concentrated on model simplification that provides sufficient accuracy based on a nonlinear discrete model. Acceleration time histories scaled to different hazard levels were used as input excitation. Finally, it was found that the simplified model provided sufficient accuracy based on a nonlinear discrete model.

3. Methodology algorithm

Numerical simulation of the Dynamic-Soil-Structure Interaction (DSSI) problems is one of the most important challenges that facing the structural and geotechnical engineers. Recently, many investigators have been used the Finite Element Model (FEM) to simulate the complex mutual dynamic interaction between superstructure, substructure, and the underneath soil [3,4,7,9,10]. Although the finite element method became one of the most important and useful tools to simulate such sophisticated problem, the appropriate model should be carefully selected. In making such analysis, it is necessary to make sure that the boundaries of the finite element model are chosen sufficiently far from the structure, so that the full effects of radiation damping are correctly represented. Alternatively, the analytical model may be provided with transmitting boundaries, which absorb any wave effects emanating from the structure and thus simulate the effects of the extensive deposit [9–13]. Fig. 1a shows a schematic diagram for the used model, where it is shown that the model is basically 2-D model with some enhancement, using viscous boundaries to behave as a simplified 3-D model. As shown in Fig. 1a, the model is supported with viscous boundaries along the planar surfaces of soil slice of width (L). Accordingly, wave energy radiating along the axis of the slice will be absorbed by material damping, while energy radiating in directions normal to axis of the slice will be absorbed by viscous boundaries (3-D simulation of energy). Lysmer et al. [11] suggested taking (L) equals the structure width.

Based on the above-mentioned precautions and boundaries, an enhanced computational model, using Finite Element Method, has been used. The computational model consists of displacement-compatible quadrilateral elements (solid elements) to simulate the soil media and linear bending (frame) elements representing the structural elements. Using Ishibashi and Zhang Formulas (1993) [14], the nonlinear relation between shear strain and both shear modulus and damping ratio was implemented. The lower boundary of the model (bedrock) is assumed to be rigid and translates horizontally or vertically according to the used earthquake acceleration time history. Fig. 1b illustrates schematic diagram for a numerical model [11], showing the combination between solid elements, frame elements, and the bedrock rigid base.

4. Mathematical formulation

The equation of motion for a finite element representation of the system can be written:

$$[M]\{\ddot{x}\} + [K]\{x\} = -\{m\}a_b - \{V\} + \{F\} - \{T\} \quad (1)$$

where $\{x\}$ are the displacements of the nodal points relative to the rigid base, $[M]$ and $[K]$ are the mass and stiffness matrices

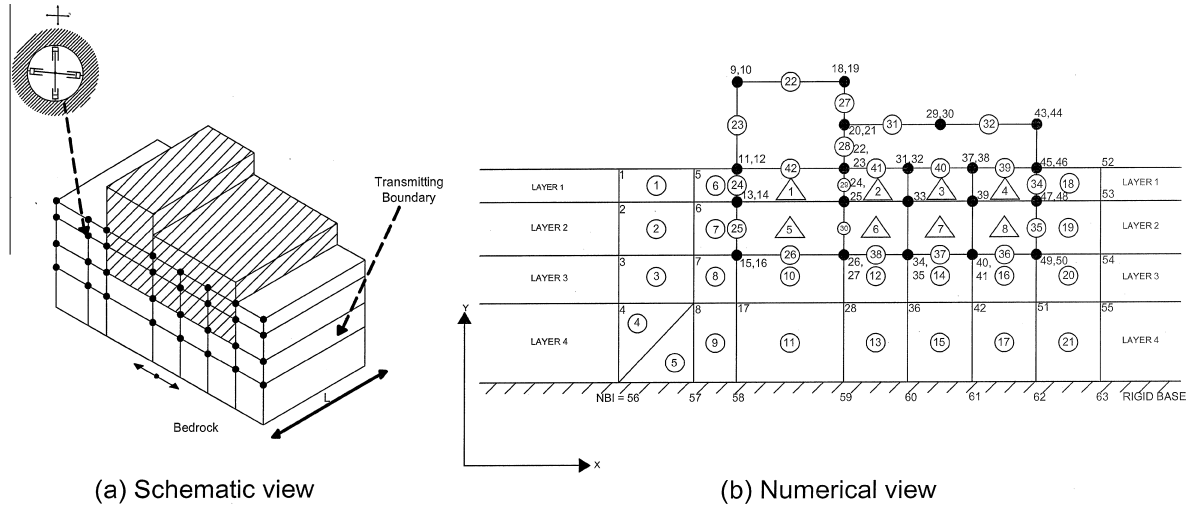

Figure 1 Schematic diagram for the used 2-D model (Simplified 3-D model), after Lysmer et al. [11].

of a slice of unit thickness, respectively. Vector $\{m\}$ is related to $[M]$ and the direction of the rigid base acceleration, a_b .

The forces $\{V\}$ represent the effect of the viscous boundaries on the planar sides of the slice (problem width, L) as follows:

$$\{V\} = \frac{1}{L}[C](\{\dot{x}\} - \{\dot{x}\}_f) \quad (2)$$

where $[C]$ is a simple diagonal matrix depending on the free field properties and $\{\dot{x}\}_f$ is the known free field velocities.

The forces $\{F_v\}$ act at the ends of the slice. They are merely the forces, which act on a vertical plane in the free field. They involve no horizontal transmission of wave energy. These forces are as follows:

$$\{F\} = [G]\{x\}_f \quad (3)$$

where $[G]$ is a simple frequency-independent stiffness matrix formed from the complex moduli in the free field.

The forces related to the energy transmission $\{T\}$ are as follows:

$$\{T\} = ([R] + [L])(\{x\} - \{x\}_f) \quad (4)$$

where $[R]$ and $[L]$ are the frequency-dependent boundary stiffness matrices introduced by Lysmer and Drake [15] and $\{x\}_f$ are the displacements of the free field. These matrices represent the exact dynamic effect of the semi-infinite viscoelastic soil system at both ends of the model. The equation of motion can be solved by the complex response method, which assumes that the input motion can be written as a finite sum of harmonics (truncated Fourier series).

4.1. Elastic equivalent linear model

The above solution procedure makes extensive use of superposition and is therefore, strictly speaking, applicable only to linear viscous elastic systems. However, the large shear deformations, which occur in soils during strong earthquakes, introduce significant nonlinear effects, and some methods must be introduced to take these effects into account. Kramer [14] illustrated that several researches have revealed the influence of soil plasticity and effective confining pressure on the shape of the modulus reduction curve. The effects of effective confin-

ing pressure (σ) and Plasticity Index (PI) on modulus reduction behavior $\left(\frac{G}{G_{\max}}\right)$ and the damping ratio (ξ) were combined by Ishibashi and Zhang (1993) in the following form:

$$\frac{G}{G_{\max}} = K(\gamma, \text{PI})(\sigma)^{m(\gamma, \text{PI}) - m_0} \quad (5)$$

$$\xi = 0.333$$

$$\times \frac{1 + \exp(-0.0145\text{PI}^{1.3})}{2} \left[0.586 \left(\frac{G}{G_{\max}} \right)^2 - 1.547 \frac{G}{G_{\max}} + 1 \right] \quad (6)$$

where (G_{\max}) is the maximum shear modulus (theoretically at zero shear strain), (G) is the secant shear modulus at shear strain (γ), $K(\gamma, \text{PI})$ and $[m(\gamma, \text{PI}) - m_0]$ are two complicated functions depend on effective shear strain of soil (γ_{eff}) and soil plasticity index (PI). According to these equations, an approximate nonlinear solution can be obtained using iterative linear analysis.

4.2. Evaluation of the effective shear strain amplitudes

The effective shear strain amplitudes (γ_{eff}) used in the equivalent linear method are taken as:

$$\gamma_{\text{eff}} = 0.65x|\gamma_{\max}| \quad (7)$$

where the factor (0.65) in Eq. (7) is purely empirical value [11,14]. The most direct procedure to evaluate the maximum shear strain amplitude (γ_{\max}) involves the computation and transfer to the time domain of the entire time history of maximum shear strain for each element. The maximum shear strain could be estimated using root mean square procedure, in the frequency domain as follows:

The root mean square value (RMS) of a function with period T is defined by:

$$\text{RMS} = \frac{1}{T} \cdot \int_0^T f^2(t) \cdot dt \quad (8)$$

where (RMS) is the root mean square value of a function with period (T). By substitution of the basic relation

$$\gamma_{\max}^2 = (\varepsilon_x - \varepsilon_y)^2 + \gamma_{xy}^2 \quad (9)$$

and

$$\text{RMS}^2(\gamma_{\max}) = \text{RMS}^2(\varepsilon_x - \varepsilon_y) + \text{RMS}^2(\gamma_{xy}^2) \quad (10)$$

The RMS values on the right-hand side can be evaluated in the frequency domain by Parseval's identity

$$\text{RMS}^2(f) = \frac{1}{2} \cdot \sum_{s=0}^{N/2} |A_s|^2, \quad s = 0, 1, \dots, N/2 \quad (11)$$

where A_s are the complex amplitudes of the Fourier series.

From Eqs. (8), (10), and (11):

$$\text{RMS}^2(\gamma_{\max}) = \frac{1}{2} \cdot \sum_{s=0}^{N/2} (|E_s|^2 + |\Gamma_s|^2) \quad s = 0, 1, \dots, N/2, \quad (12)$$

where E_s and Γ_s are the complex amplitudes of $(\varepsilon_x - \varepsilon_y)$ and (γ_{\max}) , respectively. These amplitudes are easily evaluated from the displacement amplitudes in the frequency domain in both horizontal (x) and vertical (y) directions. The estimation of the maximum shear strain can be evaluated as follows:

$$|\gamma_{\max}| \approx \frac{|\ddot{y}(t)|_{\max}}{\text{RMS}(\ddot{y})} \cdot \text{RMS}(\gamma_{\max}) \quad (13)$$

5. Applications

Fig. 2 shows the architectural drawings, statical system, and concrete sections of El-Rahman El-Raheem Mosque minaret, Egypt. This special high-rise minaret consists of reinforced concrete skeleton (60.0 m height) having base dimensions of 4.0×4.0 m. An extensive study has been carried out to investigate the effect of pile length, diameter, arrangement, and soil stiffness on the dynamic response of the minaret. Study has been extended to study factors affecting the shear base and the fundamental periodic time of the minaret. Moreover, the developed bending moment in the pile shaft due to the earthquake loading is assigned to establish the effect of pile length and diameters through a sensitivity study. Comprehensive comparison between numerical model results and conventional analysis method is illustrated.

5.1. Characters of used control motion

Based on previous numerical studies [9,10], the acceleration response spectrum defining the seismic excitation at point of control motion is used. These generated artificial time histories are based on the standard response spectrum, Uniform Building Code (1994). Fig. 3 shows the response spectrum for the used time histories in comparison with standard response spectrum of rock. The time histories for the used control motion are shown in Fig. 4, where the duration times of the generated time history are 10, 20, and 40 s, respectively, with 0.01 s time interval.

5.2. Problem simulation using finite element models

Fig. 5 shows schematic diagram for one of the constructed numerical models, where the total length of the piles is 15.0 m. Pile arrangement is (4×4) piles, in grid pattern as shown in Fig. 6. The minaret statical system and the reinforced concrete sections are shown in Fig. 2, where sections dimensions, physical, and mechanical properties are illustrated in

Table 1. Model width (L), Eq. (2) is taken equals to the pile cap width, in out of plane direction. Referring to Fig. 2a, it is clear that the model simulates the whole structure by duplicating the element frame area and inertia, as the minaret in 3-D consists of two successive frames. Similarly, the pile section is multiplied by (4) to simulate the effect of the successive four piles (in the out of plan direction).

5.3. Physical and mechanical soil properties

To carry out a comprehensive parametric study, the physical and mechanical soil properties for the upper soil formation (up to 20 m depth) are selected to cover a wide range of sandy soil types (loose, med. dense, dense and very dense). Table 2 shows the different physical and mechanical soil properties. For the deeper soil layer, it is considered that the soil layer is formed of very dense sand (S4).

6. Study results

In general, the main study has been carried out considering the following:

- Properties of soil type (S2) are selected to simulate the upper soil formation (up to 20 m depth, measured from the ground surface). The effect of the other soil types is shown in a separate section.
- The piles are arranged in grid pattern 4×4 piles, as shown in Fig. 6. Two extra arrangements are examined considering grid pattern 6×6 and 8×8 piles.
- The used generated earthquake time history is GEQ(II), Fig. 4b. Extended studies have been carried out to establish the differences between results using GEQ(I) and GEQ(III). There was a slight tolerance between results (up to 12%).
- The generated earthquake time histories are scaled to obtain maximum base acceleration ($a_{\max} = 0.125$ g) at the level of the pile cap.

6.1. Lateral dynamic response of minaret crown

6.1.1. Effect of pile length

Fig. 7 shows the relation between the maximum horizontal dynamic responses of minaret crown and the pile length, considering different pile diameters. It is very important to mention that zero pile length means using only shallow raft foundation with dimensions similar to the pile cap as shown in Fig. 6. Examining the study results, it could be established the following:

1. Deep foundation using piles has a major effect on reducing the dynamic response of the minarets. It could be reduced by about 60%, in case of using piles having 20.0 m length and 1.0 m diameter.
2. The dynamic response of the minaret is highly affected by the pile length. It is very clear that even short pile has a well considerable effect (about 32–40% reduction). This notice reflects the fixation effect of even short piles on the complex interaction between the piles and the internal confined soil mass. It also illustrates the benefits of using short crushed stone piles that was used before underneath the ancient Islamic minarets. These crushed stone piles are well known as “Roman or Alex. Piers” in Egypt.

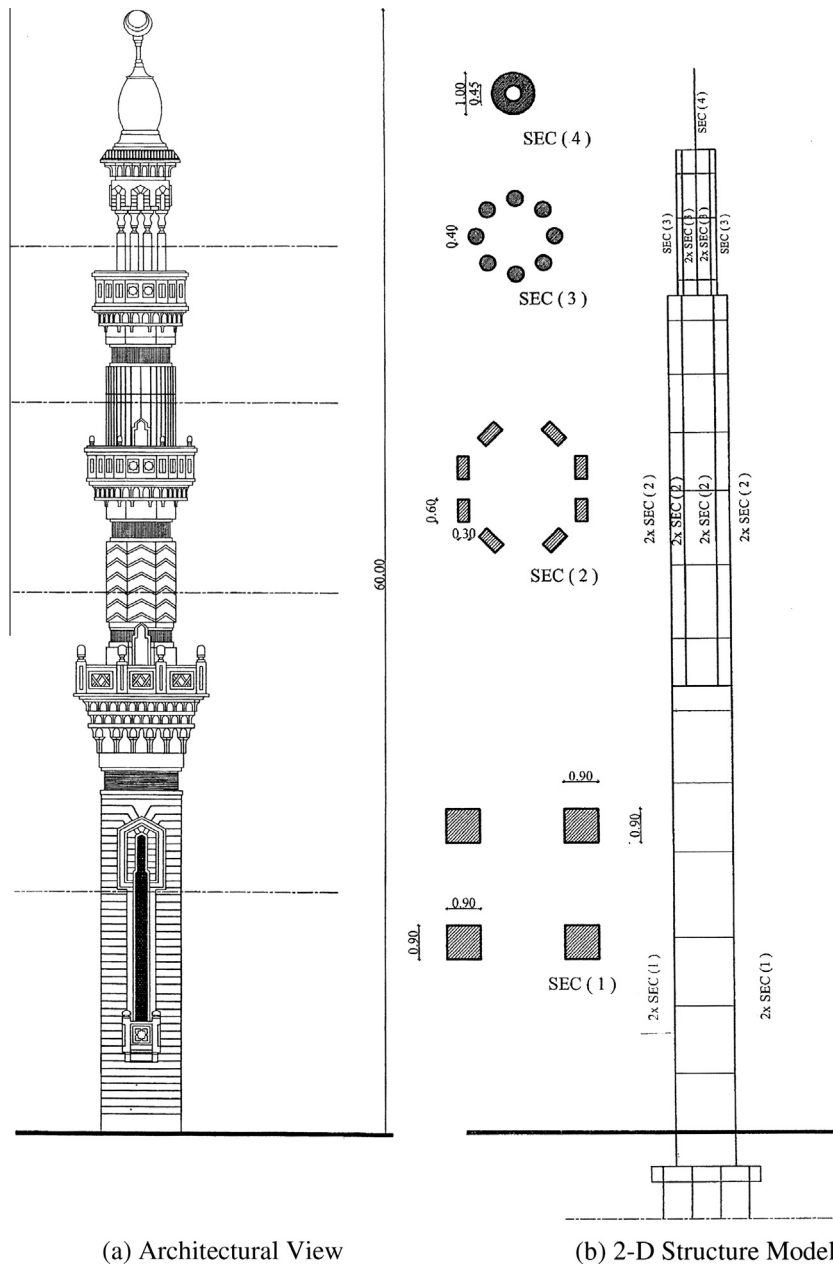

Figure 2 Architectural drawings, 2-D structure model, and concrete sections.

3. For the recent study, 15.0 m pile length is sufficient to be the economical pile length.

6.1.2. Effect of pile diameter

To clearly investigate the effect of pile diameter, an additional set of curves was plotted, as shown in Fig. 8. Examining this figure, it could be established that the pile diameter has a slight considerable effect on reducing the lateral dynamic response of the minaret, especially for small diameters (40 and 60 cm). For larger diameters (80 and 100 cm), it is clear that increasing pile diameter has a negligible effect.

6.1.3. Effect of pile arrangement (number of piles)

Two additional arrangements (6 × 6 and 8 × 8 piles) have been studied to investigate the effect of pile arrangement or the total

number of piles. Study results are shown in Fig. 9, where it could be established the following:

1. The two additional studied pile arrangements have a similar behavior in comparison with (4 × 4 piles) arrangement. Similarly, the pile length has the major considerable effect.
2. In comparison with the effect of the pile length, the total number of piles has not a significant effect on the dynamic response of the minaret.

6.1.4. Effect of soil stiffness

Fig. 10 shows the effect of changing soil shear stiffness on the maximum horizontal dynamic responses of minaret crown. The relations are plotted considering different pile lengths as well as the case of no piles. Results illustrate the great effect

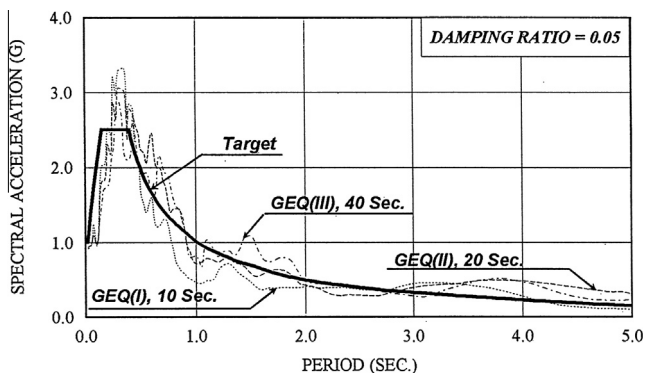

Figure 3 Acceleration response spectrum of the used generated earthquake compared with the UBC, 1994 (after Abdel-Motaaal [10]).

of soil stiffness on the minaret dynamic response, especially for the region of loose and med. dense sand.

6.2. Fundamental periodic time of the minaret

The fundamental periodic time (FPT) of the structures has a major effect on the dynamic response of the structures, especially if its values fall within the range of the earthquake response spectrum peak values. At this section, the minaret (FPT) is estimated using Fourier Amplification Function. The results of the study are given as follows:

6.2.1. Effect of soil stiffness

Initially, studies have been carried out considering shallow foundation type (without piles) to investigate the effect of shallow soil stiffness. Fig. 11 shows a relation between (G_{max}) and the estimated values of the minaret (FPT), where it could be established the following:

1. The soil stiffness has a major effect on changing the (FPT) of the structure. This notice could be clarified as increasing the shear modulus has a major effect on increasing the degree of structure support fixation. Consequently, foundations on loose or med. dense soil act as partially fixed supports.
2. Additional study is carried out considering full fixation of the minaret base, neglecting soil effect (fixed supports). The estimated value of the (FPT) was (1.95). Referring to Fig. 11, it could be established that the values of the (FPT) are (2.5) & (2.1) for dense and very dense sand, respectively. In comparison with the results of using fixed supports, it is clear that dense and very dense soil formations tend to achieve the full fixation situation.

6.2.2. Effect of piles

Considering the effect of the pile length and diameter, extra studies are carried out to plot additional set of relations as shown in Fig. 12. The surface soil is selected med. dense formation to show obviously the effect of the piles on changing the structure fixation situation. These curves show the following:

1. The pile lengths have a great effect on changing the minaret (FPT), especially for the range between 5 and 15 m pile length.

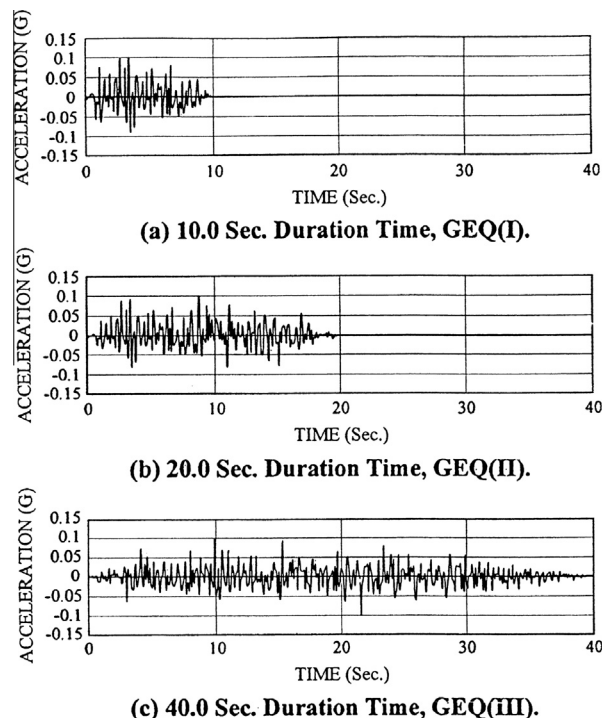

Figure 4 Time histories for the used generated control motion (after Abdel-Motaaal [10]).

2. Pile diameter has also a considerable effect on the foundation fixation, especially for small diameters (0.4 and 0.6 m).
3. Increasing both pile length and diameters tends to achieve the ideal full fixation situation or tends to get similar results compared with shallow foundation rested on very dense soil formation.

6.3. Shear forces at minaret base

The above-mentioned results illustrate that piles have considerable effect on (FPT). Accordingly, it was so important to study the pile effect on the values of base shear. Fig. 13 illustrates the relations between pile length and the maximum shear force at the minaret base, considering different pile diameters. It could be noticed the following:

1. Base shear is considerably increased as a function of increasing structure fixation (up to 18.2%).
2. Effect of pile length is more considerable than pile diameter on the base shear values.

6.4. Bending moment along pile shaft

6.4.1. Effect of pile length and diameter

As mentioned in the previous sections, the piles have a major effect on achieving fixation for the minaret supports. Consequently, it is very important to study the developed bending moments along pile shaft and factors affecting their values. Fig. 14 shows a relation between the max. (max. bending moment), pile lengths, and diameters. Examining these curves, it could be established the following:

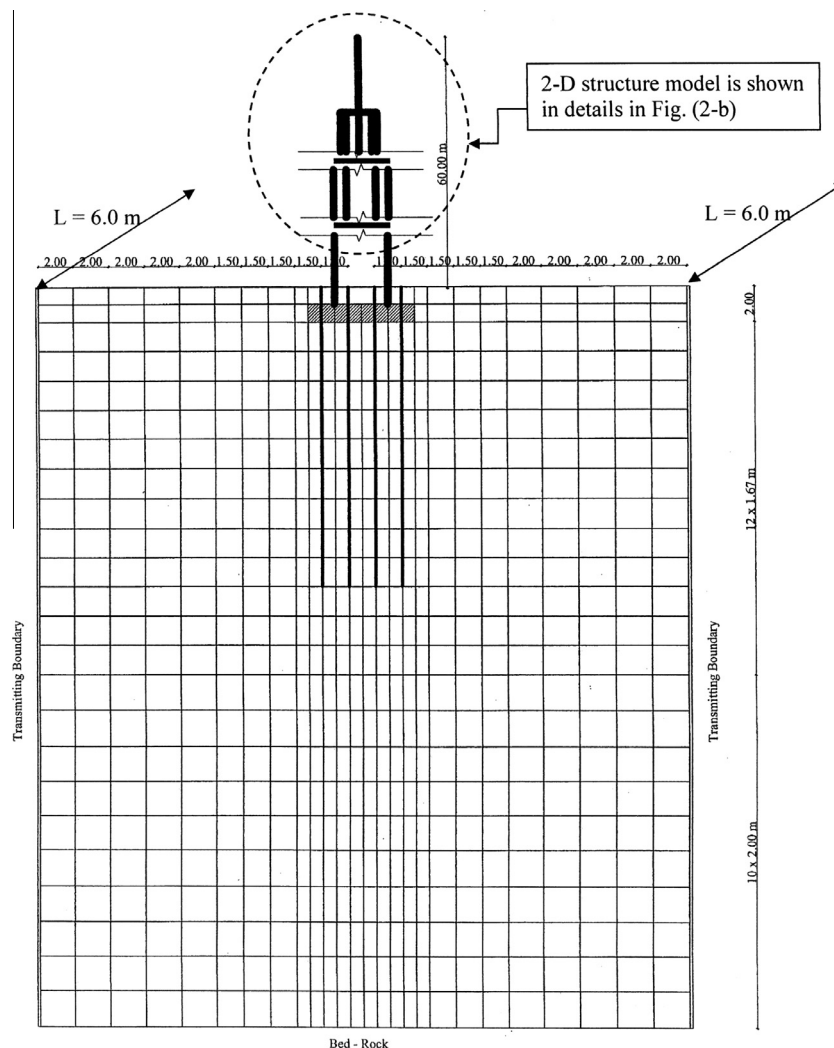

Figure 5 Schematic diagram for one of the constructed numerical model, total length of the piles = 15.0 m, considering pile arrangement 4×4 piles.

1. Increasing pile length, which reflects its ability to exert foundation fixation, is responsible for developing extra bending moments. This notice could be noticed, considering the different pile diameters up to 15 m pile length.
2. A considerable reduction in the values of the developed bending moments is mentioned in case of using long piles (20 m length). This notice could be clarified as 15 m pile length may be considered (for such case) as a sufficient fixation length. Any additional increase for the pile length may produce some kind of redistribution of the soil lateral dynamic resistance and hence reducing the developed bending moment. Moreover, the penetration of the 20-m pile length into the lower very dense sand layer (2.0 m penetration) may affect the pile fixation. Accordingly, a comprehensive study should be carried out by the designer to get the optimum economical design and choose between increasing pile length (20 m, for example) and decreasing pile reinforcement or vice versa.
3. Pile diameter has a highly considerable effect of increasing the developed bending moment. It reflects the pile diameter effect on increasing the pile flexural capacity.
4. Finally, it is not recommended to use large diameter piles, as increasing pile diameters has not a considerable effect

of reducing the lateral dynamic response (Fig. 8). Contrary, it increases the developed bending moment and hence the pile reinforcement.

6.4.2. Effect of soil stiffness

Fig. 15 shows the effect of changing soil shear stiffness on the max. (max. bending moment) along pile shaft. The relations are plotted considering different pile lengths. Results illustrate the great effect of soil stiffness on the developed bending moment along pile shaft, especially for loose and med. dense sand. This notice could be clarified as the lateral resistance of loose and med. dense sand is very low. Consequently, the pile will be subjected to large deformations under seismic excitation and hence relatively high bending moment values.

6.5. Comparison between study results and conventional design method

Conventionally, designers divide such problem into two phases of analysis as follows:

1. The first phase focuses on the structural analysis of the minaret structure. Dynamic analysis could be done using

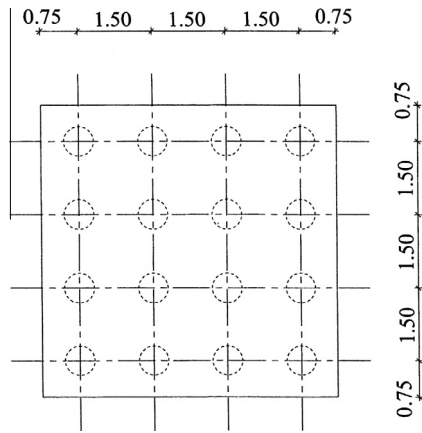

Figure 6 Arrangement of piles and pile cap.

equivalent static method, spectral, or time history analysis. They commonly simulate and suppose the foundation and the underneath soil as fixed supports.

2. In the second phase, the support reactions are used to design the foundation that may be shallow isolated footings, raft, or pile cap rested on piles.

In this section, the recent study results are compared with a simple design method based on the Egyptian Code of Loading [16]. Modal Spectral analysis was used to estimate the base shear depending on the minaret (FPT), max. ground acceleration (0.125 g), structure ductility, and soil type. The importance factor (I) is selected equals 1.0 to cancel any effect of this factor on increasing the base shear. Through this simple analysis, shear base is estimated equal 31.9 ton. Referring to Fig. 13, it could be established that the estimated shear base, using the proposed numerical modal, ranges between 23.8 and 28.14 ton. It means that considering the effect of soil

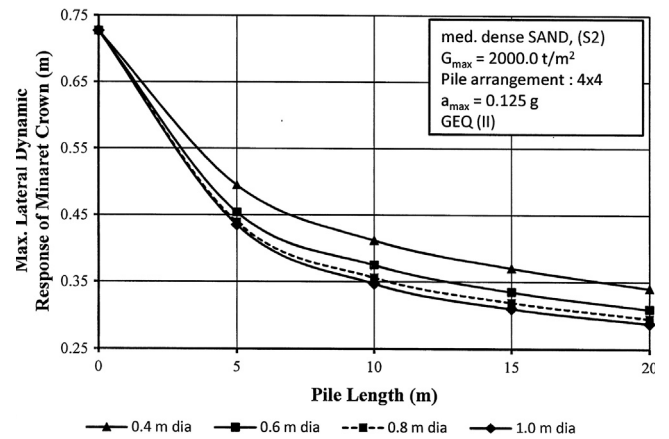

Figure 7 Effect of pile length on the max. lateral dynamic response of minaret crown, considering different pile diameters.

and foundation type on the degree of fixation of the structure could save about (25.4–11.8%) of the estimated shear base forces. Consequently, it will have its economical impact on the designed concrete sections.

As a second step of the conventional analysis, the estimated base shear forces (31.9 ton) are divided equally on the total no of piles (16 piles). Poulos & Hull (1989) method [17] is used to estimate the maximum bending moment along pile shaft due to this lateral load. This method is explained in the Egyptian Code of Soil Mechanics and Foundation [17].

In summary, the maximum bending moment (M_{max}) could be estimated as follows:

$$M_{max} = H \cdot L_e \cdot I_5 \quad (14)$$

where (H) is the horizontal load per pile, (L_e) is the effective pile length, and (I_5) is an influence factor depends on soil type and the pile ductility (flexible or rigid).

Table 1 Dimensions and properties of minaret concrete sections.

Section ID	Dimensions (cm)	Unit weight (t/m^3)	Poisson's ratio, ν	Modulus of elasticity, E (t/m^2)	Damping ratio
Sec (1)	90 × 90	2.5	0.16	2,100,000	5.0%
Sec (2)	30 × 60				
Sec (3)	40 cm dia.				
Sec (4)	Hollow circle Outer dia. = 100 cm Inner dia. = 45 cm				
Horizontal beams	30 × 90 and 25 × 70				

Table 2 Physical and mechanical soil properties.

Soil type	Soil description	Dry unit weight, γ_d (t/m^3)	Poisson's ratio, ν	Shear modulus, G_{max} (t/m^2)	Soil modulus of elasticity, $E_s = 2(1 + \nu) \bullet G_{max}$ (t/m^2)
S1	Loose sand	1.60	0.40	1000.0	2800.0
S2	Med. Dense sand	1.70	0.36	2000.0	5440.0
S3	Dense sand	1.80	0.33	5000.0	13300.0
S4	Very dense sand	1.90	0.30	10000.0	26000.0

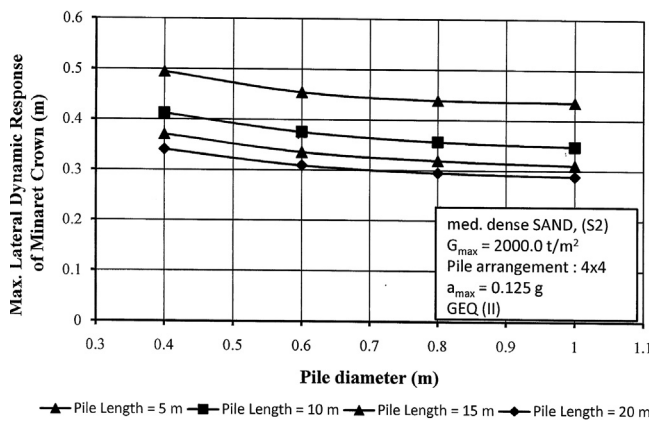

Figure 8 Effect of pile diameter on the max. lateral dynamic response of minaret crown, considering different pile diameters.

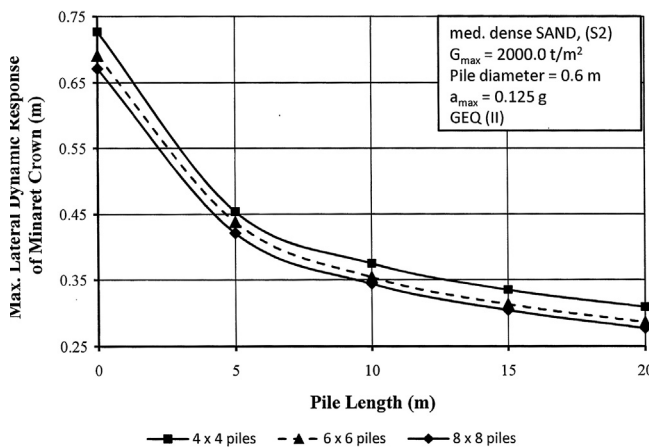

Figure 9 Effect of pile length on the max. lateral dynamic response of minaret crown, considering different pile arrangements.

Fig. 16 shows a comparison between the numerical analysis results using finite element method (FEM) and the used simple conventional method. Through this figure, the following could be established:

1. For small diameter piles ($d = 0.4$ m), the estimated values of maximum bending moment using (FEM) are less than conventional method results. This notice could be clarified as the base shear, considering flexible foundation, is less than the estimated values using conventional analysis and hence the associated bending moment. Consequently, economical impact could be gained considering (FEM) results.
2. For larger diameters ($d = 0.6, 0.8$ and 1.0 m), and according to the relative stiffness between pile and soil, it is found that these piles could not be classified neither flexible nor rigid (according to Poulos & Hull limits [17]). It is located at the intermediate zone (semirigid – semiflexible piles). Consequently, two border lines are estimated and plotted;

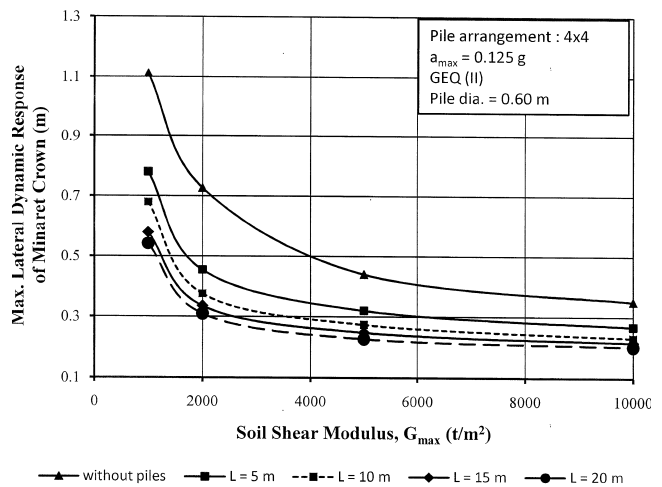

Figure 10 Effect of soil shear modulus, G_{max} on the max. lateral dynamic response of minaret crown, considering different pile lengths, L .

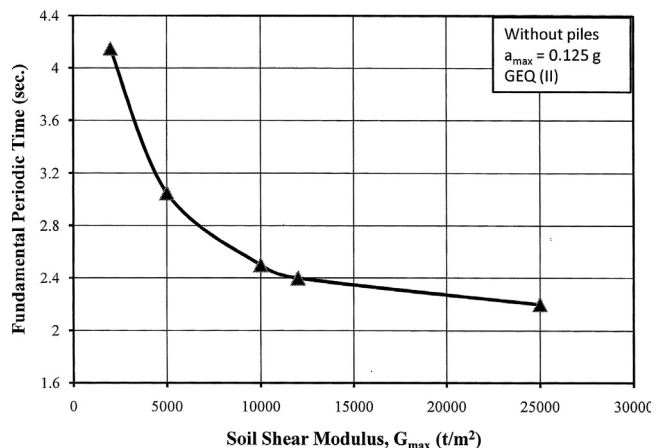

Figure 11 Effect of soil shear modulus, G_{max} , on the fundamental periodic time (FPT), (case without piles).

- the first one concerns the lower limits of (M_{max}) using flexible pile parameters and ($d = 0.6$ m). On the other side, the upper limit is assigned considering rigid pile diameter having ($d = 1.0$ m). Fig. 16 shows the upper and lower limits and the intermediate shaded zone. Referring to this figure, it could be noticed that results obtained by (FEM) are nearly located between the upper and lower limits estimated by (Poulos & Hull 1989). Moreover, results of (0.6 m) piles tend to match with the lower boundary that represents flexible pile situation. Contrary, the results of large rigid pile ($d = 1.0$) tend to match with the upper limits that represents rigid pile situation.
3. Results discussed in the last point show the benefits of using the (FEM), where the relative stiffness between pile and surrounding soil is taken into consideration. Consequently, this model solves problems facing the designer to deal with this gray zone (semirigid – semiflexible piles).

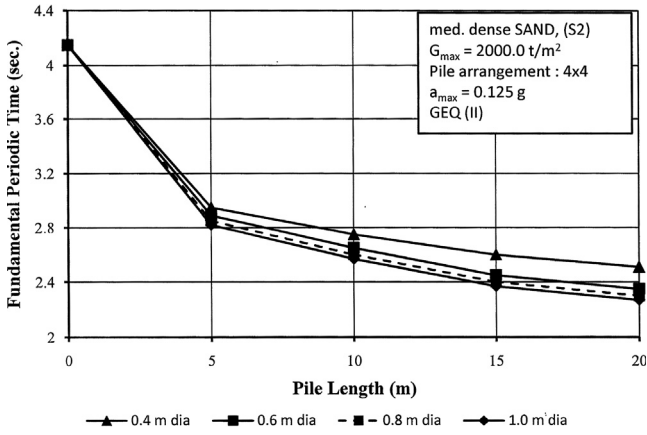

Figure 12 Effect of pile length on the fundamental periodic time (FPT), considering different pile diameters.

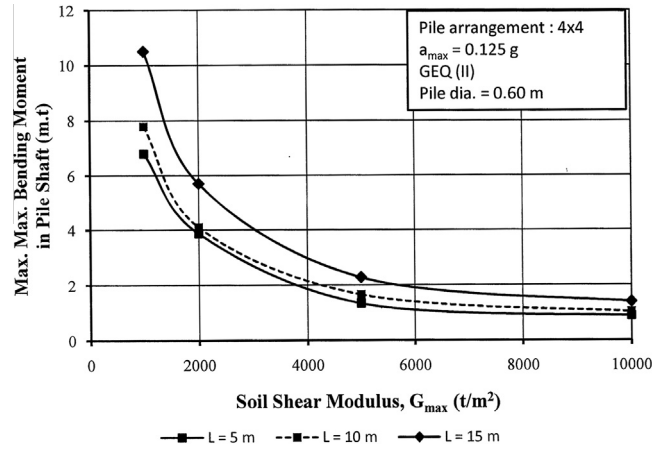

Figure 15 Effect of soil stiffness on the max. max. values of the developed bending moments along pile shaft.

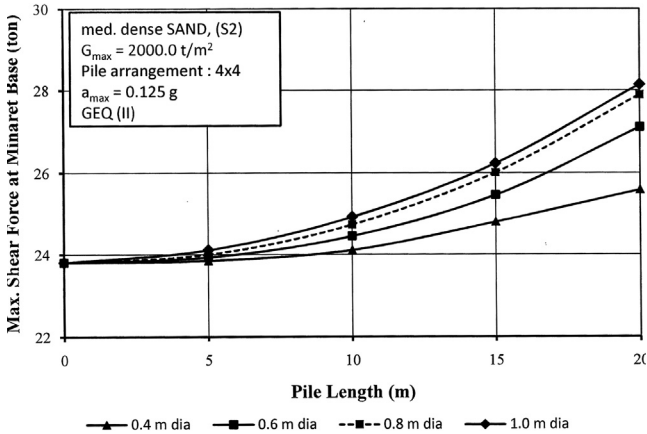

Figure 13 Effect of pile length on the max. shear forces at minaret base, considering different pile diameters.

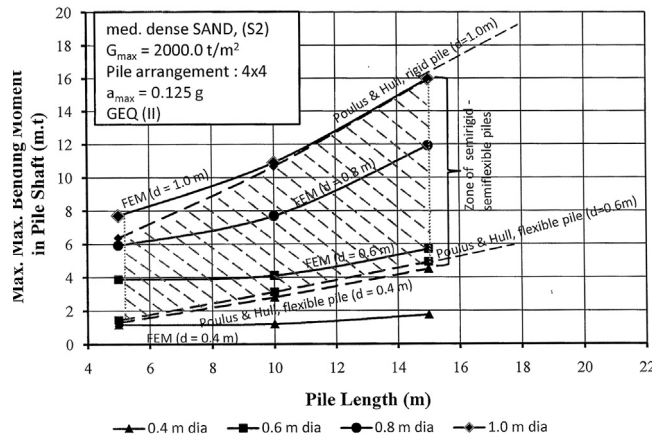

Figure 16 Comparison between numerical analysis results using finite element method (FEM) and (Poulos & Hull, 1989) conventional method.

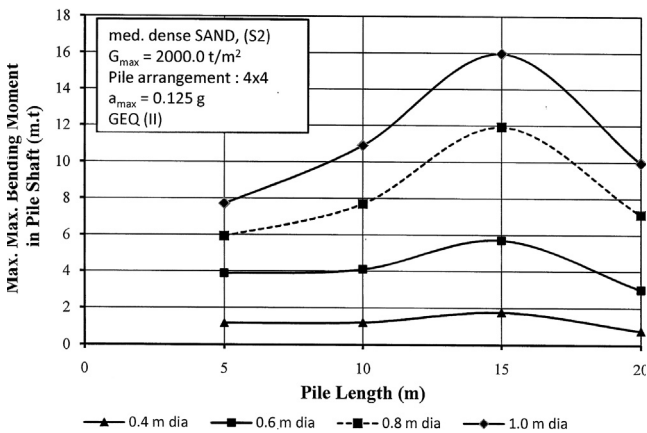

Figure 14 Effect of pile length on the max. max. values of the developed bending moments along pile shaft.

7. Conclusion

This study is focusing on studying the effect of using pile foundation on the dynamic response of the high-rise Islamic Mosque Minarets. A sophisticated mathematical model, based on the equivalent linear analysis, has been used. This mathematical model is capable of taking into account the nonlinear effect of the effective shear strain amplitudes, confining pressure, and plasticity index of soil on shear modulus reduction behavior and damping ratio. The computational model consists of displacement-compatible quadrilateral elements (solid elements) to simulate the soil media and linear bending elements representing the structural elements. The lower boundary of the model (bedrock) is assumed to be rigid and translates horizontally or vertically according to the used earthquake acceleration time history. Three artificial earthquakes' time histories have been used as a control motion at the bedrock surface.

These generated artificial time histories are based on the standard response spectrum, Uniform Building Code (1994). The equation of motion has been solved by the complex response method, which assumes that the input motion can be written as a finite sum of harmonics (truncated Fourier series).

The used numerical model is capable of solving the sophisticated dynamic problem through a full dynamic interaction between structure, foundation, soil, and base shear excitation. Moreover, the model has the following advantages:

- (i) Using viscous boundaries, it could be simplify the 3-D analysis to an enhanced 2-D analysis and hence saving the designer effort and the needed computer memory capacity.
- (ii) The model has the capabilities to change soil properties with depth and simulate the soil stratification.
- (iii) Dynamic nonlinear behavior of soil properties (stiffness and damping) and energy-absorbing characteristics could be considered simply using the equivalent linear model.
- (iv) The dimensions of the finite element mesh could be drastically reduced using the transmitting boundaries.

On the other hand, the model has its capability limits (disadvantages) such as

- (i) It may be unable to simulate 3-D sophisticated problems that contain structural variation in the out of plan direction.
- (ii) Not suitable for dynamic problems associated with water pressure generation due to volume change problems, such as liquefaction.
- (iii) Plastic or residual deformation due to seismic excitation cannot be estimated using this model.

The minaret of El-Rahman El-Raheem Mosque, Egypt was selected to carry out the target study. This special high-rise minaret consists of reinforced concrete skeleton (60.0 m height) having (4.0 × 4.0 m) base dimensions. A wide range of dry sand formation properties (loose to very dense) was selected to simulate the upper sand formation (up to 20 m depth). An extensive study has been carried out to investigate the effect of pile length, diameter, arrangement, and soil stiffness on the dynamic response of the minaret. Study has been extended to study factors affecting the fundamental periodic time (FPT) of the minaret and the fixation of its support. Moreover, the developed bending moment (due to earthquake) along pile shaft was assigned to establish the effect of pile length and diameters through a sensitivity study to choose the optimum and economical design. Comprehensive comparison between numerical model results and conventional analysis method is illustrated. Through the analysis of the study results, the main conclusions are listed below:

1. Deep foundation using piles has a highly considerable effect on reducing the dynamic response of the minarets. It could be reduced by about 60%, in case of using piles with 20.0 m length and 1.0 m diameter.
2. The dynamic response of the minaret is highly affected by the pile length. Study results show the effect of even short

piles on the complex interaction between the piles and the internal confined soil mass. Their presence is directly affect the fixation of the minaret foundation (support).

3. Study results show that there is an optimum pile length, where beyond this value, the effect of increasing the pile length is not significant.
4. The soil stiffness has a major effect on changing the structure fundamental periodic time (FPT). Increasing the shear modulus has a high and direct effect on increasing the degree of fixation of the structure support. It means that loose and med. dense soil act with the foundation as a partially fixed support. In comparison with the ideal fixation situation, it is clear that dense and very dense soil formations tend to satisfy the full fixation situation.
5. The pile lengths have a great effect on changing the minaret (FPT). Increasing both pile length and diameters tend to satisfy the ideal full fixation situation. Studies clarify also that fixation due to pile presence has its considerable effect of increasing the shear forces at the minaret base.
6. Increasing pile length, which reflects its ability to exert foundation fixation, is responsible for developing extra bending moments along pile shaft.
7. From economical point of view, it is not recommended to use large diameter piles, as increasing pile diameters has not a considerable effect of reducing the lateral dynamic response. Contrary, it increases the developed bending moment and hence the pile reinforcement.
8. Comprehensive study has been carried out to compare between results of the FEM and one of the conventional method of analysis. Study showed that considering the effect of soil and foundation type on the degree of fixation of the structure could save about (25.4–11.8%) of the estimated shear base forces. Consequently, it will have its economical impact on the structure concrete sections as well as pile sections.
9. There is a good matching between the estimated values of the maximum bending moments, along pile shaft, using both (FEM) and (Poulos & Hull, 1989) conventional method. Moreover, results show the benefits of using the (FEM), where the relative stiffness between pile and surrounding soil is taken into consideration. Consequently, this model solves problems facing the designer to deal with this gray zone (semirigid – semiflexible piles).

References

- [1] Behrens D, Abouseif A. *The Minarets of Cairo*. The American University in Cairo Press; 1985.
- [2] Elwan SH. Seismic response of historical masonry minarets. Ph.D. thesis, Faculty of Engineering, Ain Shams University, Cairo; 1996.
- [3] Chmielewski T, Gorski P, Beirow B, Kretschmar J. Theoretical and experimental free vibrations of tall industrial chimney with flexibility of soil. *Journal of Engineering Structures* 2005;27:25–34.
- [4] Acar R, Livaoglu R, Dogangum A, Sezen H. The effect of subsoil on the seismic response of reinforced concrete cylindrical minarets. In: Fifth international conference on seismology and earthquake engineering, international institute of earthquake engineering and seismology (IIEES), Tehran, Iran; 2007.

- [5] Dogangun A, Acar R, Sezen H, Livaoglu R. Investigation of dynamic response of masonry minaret structures. *Bull Earthquake Eng* 2008;6(3). August 2008.
- [6] Sezen H, Acar R, Dogangun A, Livaoglu R. Dynamic analysis and seismic performance of reinforced concrete minarets. *J Eng Struct* 2008;30:2253–64.
- [7] Hacıfend K, Fahri B. Stochastic dynamic response of masonry minarets subjected to random blast and earthquake-induced ground motions. *J Struct Des Tall Special Build* 2011;20(6):669–78.
- [8] Tabeshpour MR. Nonlinear dynamic analysis of chimney-like towers. *Asian J Civ Eng (Build Housing)* 2012;13(1):97–112.
- [9] Macky T, Mokhtar A, Fayed M, Abdel-Motaal M. Controlling the dynamic response of structures using foundation ties. In: Eighth int. colloquium on structural and geotechnical engineering, Ain Shams University, Cairo, Egypt; 1998.
- [10] Abdel-Motaal M. Soil effect of the dynamic behavior of framed structures. Ph.D. Thesis, Faculty of Engineering, Ain Shams University, Cairo; 1999.
- [11] Lysmer J, Utake T, Tsai C-F, Seed HB. Computer program for approximate 3-D analysis of soil-structure interaction problem. Report No. EERC 75-30, Collage of Engineering, University of California, Berkeley, California, USA; 1975.
- [12] Kausel E, Roesset JM, Christian JT. Nonlinear behavior in soil-structure interaction. *J Geotech Eng, ASCE* 1976;102(GT11):1159–70.
- [13] Chen ATF. Transmitting boundaries and seismic response. *J Geotech Eng, ASCE* 1985;111(2):174–80.
- [14] Kramer SV. *Geotechnical earthquake engineering*. Prentice-Hill, Inc.; 1996.
- [15] Lysmer J, Drake LA. A finite element method for seismology. *Method Comput Phys* 1972;11 [chapter 6].
- [16] Egyptian Code of Loads. Housing and Building Research Center (HBRC), Ministry of Housing, Egypt; 2010.
- [17] Egyptian Code of Soil Mechanics and Foundation. Housing and Building Research Center (HBRC), Ministry of Housing, Egypt; 2001.



Mohamed Ahmed Abdel-Motaal works as an Associate Professor of Geotechnical Engineering at the Department of Structural Engineering, Ain Shams University, Cairo, Egypt. Since April 2012, he was appointed as a director of the Soil Mechanics and Foundation Engineering Consulting Unit (SMFU) at Ain Shams University. He is a member of the experts' board for updating the Egyptian Code of Soil Mechanics and Foundation Design (Part 6). His research interest is Soil Dynamics, Geotechnical Earthquake Engineering and Soil Stabilization.